

Date: 8/07/06  
Model #: PCA304836S

3048/36 ASSEMBLY  
ALL POLYMER CONCRETE

**COVER FEATURES:**

- \* STANDARD LOAD RATING: 20,800 POUND WHEEL LOAD ON 10 X 20 PLATE
- \* POLYMER CONCRETE CONSTRUCTION
- \* WEIGHT = 110 POUNDS (EACH HALF)
- \* 4 BOLT DOWN LOCATIONS
- \* COLOR = CONCRETE GREY
- \* NON-SKID SURFACE

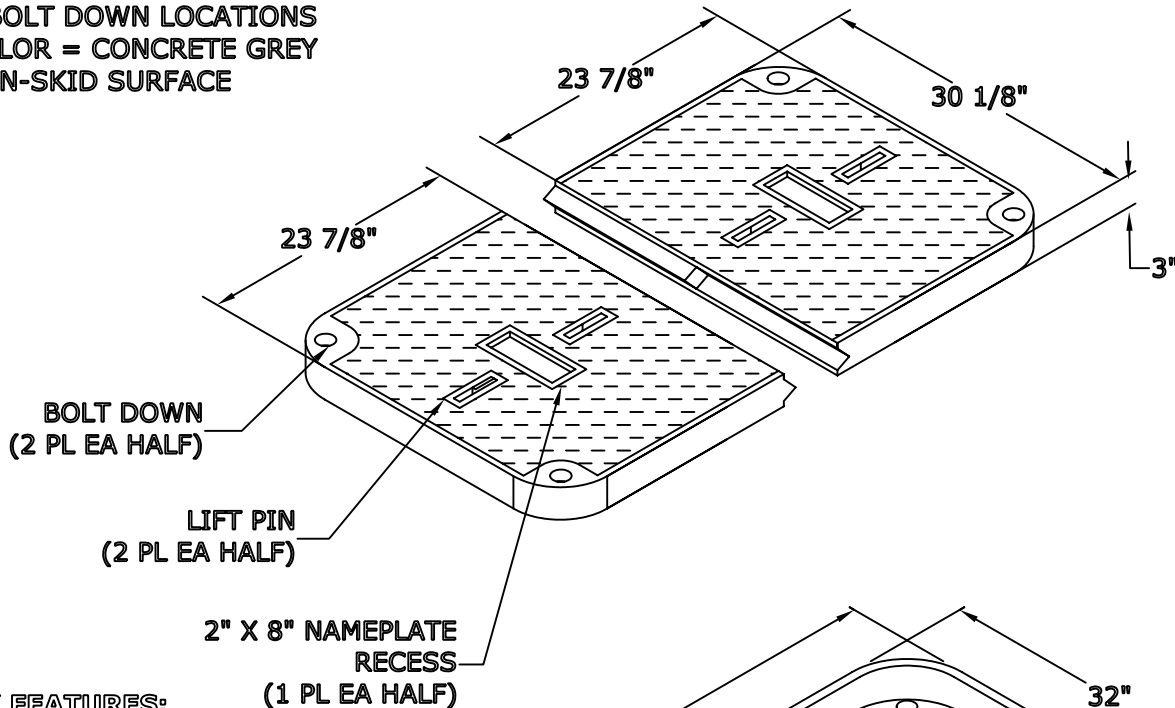

**BOX FEATURES:**

- \* POLYMER CONCRETE CONSTRUCTION
- \* STACKABLE
- \* APPROX. WEIGHT 385 LBS.

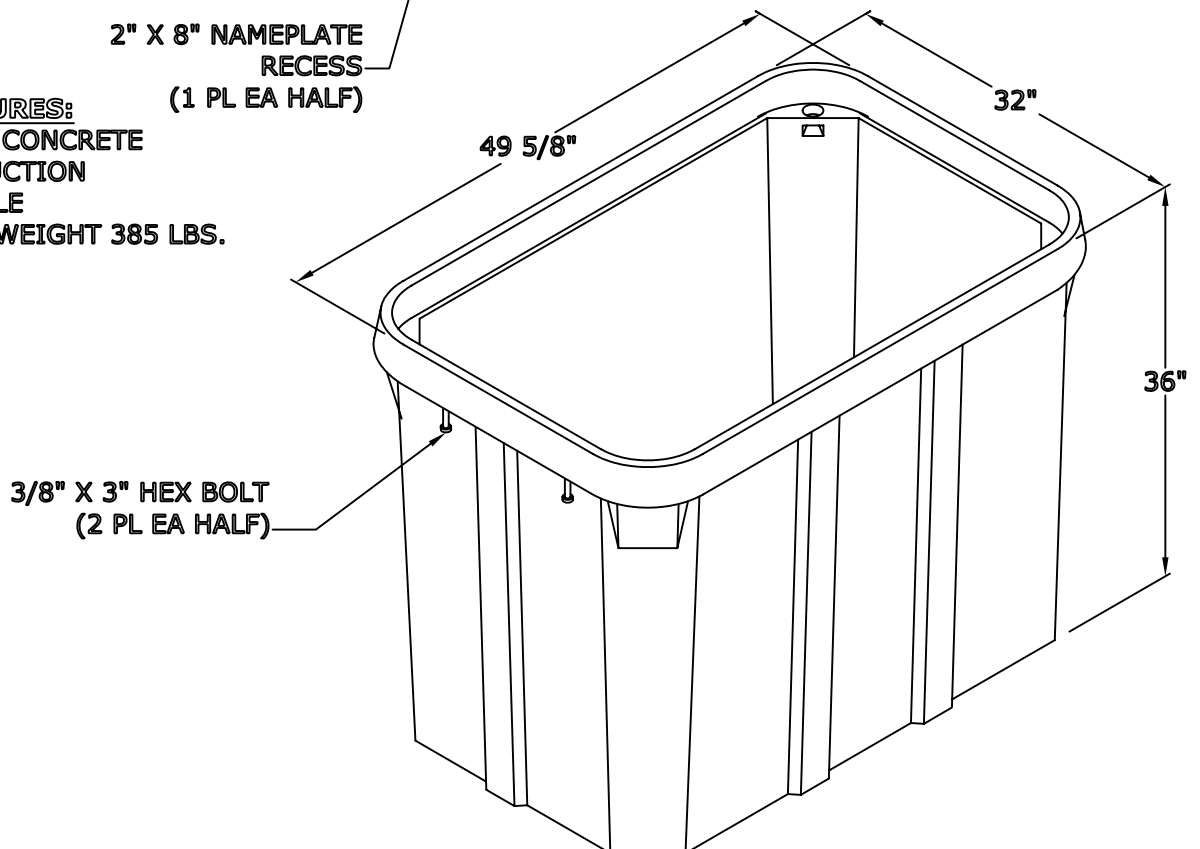

NewBasis  
2626 Kansas Ave.  
Riverside, CA 92507

Phone (951)787-0600  
Fax (951)787-0632  
www.newbasis.com

**newbasis**