



## **PREFORMED** LINE PRODUCTS

### **Section 20 – Dead-end & Accessories**

#### Table of Contents

<b>Figure-8 Messenger Dead-end .....</b>	<b>20-2</b>
<b>GUY-GRIP® Dead-end .....</b>	<b>20-3</b>
<b>Big-Grip Dead-end.....</b>	<b>20-6</b>
<b>False Grip Dead-end.....</b>	<b>20-8</b>
<b>Open Wire Dead-end .....</b>	<b>20-9</b>
<b>Drop Wire Dead-end .....</b>	<b>20-10</b>
<b>C-Rural/Buried Line Wire Dead-end.....</b>	<b>20-10</b>
<b>Telegrip.....</b>	<b>20-11</b>
<b>Custom Coaxial Dead-end .....</b>	<b>20-12</b>
<b>Pulling Eye .....</b>	<b>20-13</b>
<b>Safety Guy-Wire Dispenser .....</b>	<b>20-14</b>



# Dead-ends for Figure-8 Messenger

## Dead-ends for Figure-8 Drop Wire Messenger

There is no quicker, easier way to attach Figure-8 drop wire or cable than with PREFORMED™ Dead-ends for Figure-8 RG-59/U coaxial cable messenger. Strip the messenger to accommodate the Dead-end and wrap on for a secure and permanent installation. The helical shape will insure low distribution of holding stresses and prevent premature fatigue breakage. If required, False or Double Dead-ending can be accomplished without cutting the wire, a feature that is exclusive with all helically designed PREFORMED Dead-ends.



Catalog Number	Material	Cable Diameter	Units	Wt./Lbs.
			Per Carton	
DE-2525	Galvanized Steel	.051"	200	7
DE-2505	Galvanized Steel	.063"	200	8
DE-2506	Galvanized Steel	.083"	200	8
GDE-2501	Galvanized Steel	.109"	100	9
GDE-2503	Galvanized Steel	.134"	100	15
DE-8500	Stainless Steel	.063"	200	5
DE-8501	Stainless Steel	.083"	200	5

# GUY-GRIP® Dead-end

GUY-GRIP Dead-ends, installed at the top, the breaker and the anchor, provide today's most effective method for securing guy strand. This unique, one-piece dead-end is neat in appearance and free from bolts or high-stress holding devices. The GUY-GRIP Dead-end was the first to offer the cabled loop, a feature that provides more durability, easier tensioning and adaptability to multiple guying.

GUY-GRIP Dead-ends are made of the same material as the strand to which they are applied. They should be used on hardware that is held in a fixed position. The fitting should not be allowed to rotate or spin about the axis of the strand. They should not be used as tools including come-alongs, pulling-in grips, etc.

## Nomenclature:

### Cross-over Marks:

(A)—Indicates starting point for application on smaller diameter fittings.

(B)—Indicates alternate starting point for application on larger diameter fittings.

**Cabled Loop:** Furnished as standard, all sizes.

**Pitch Length:** One complete wrap.

**Short Leg-Long Leg:** Identifies rods belonging to each leg, after application.

**Color Code and Length:** Assists in identification of strand size, corresponding to tabular information appearing on price page.

**Identification Tape:** Shows catalog number, nominal sizes.

## Nomenclature

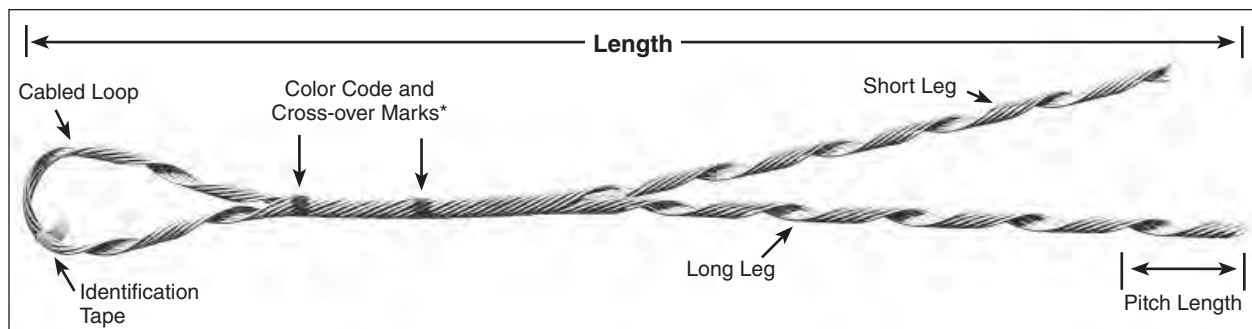

## Suggested Hardware Dimensions for Cabled-loop Guy-grip Dead Ends

Nominal Strand Sizes			Seat Dimensions (fig 1 & 2)			
Dead-end Diameter Range (mm)	Galvanized/ Galfan Steel	Aluminum-Clad Steel	Max. seat diameter with dead-end at second crossover mark (mm)	Minimum Groove Diameter (mm) (fig. 2)	Minimum Groove Diameter (mm) (fig. 3)	Minimum Hole Diameter* (mm) (fig. 3)
.123"- .143" (3.1-3.6)	1/8"	—	—	3/16" (4.7)	3/16" (4.7)	1/4" (6.3)
.144"- .173" (3.7-4.4)	5/32"	—	2 1/2" (64)	1/4" (6.3)	1/4" (6.3)	5/16" (7.9)
.174"- .203" (4.4-5.2)	3/16"	—	2 1/2" (64)	1/4" (6.3)	1/4" (6.3)	3/8" (9.5)
.204"- .230" (5.2-5.8)	7/32"	3 #10, 4M3	2 1/2" (64)	5/16" (7.9)	5/16" (7.9)	3/8" (9.5)
.231"- .259" (5.9-6.6)	1/4"	7 #12, 6M	2 1/2" (64)	5/16" (7.9)	5/16" (7.9)	7/16" (11.0)
.260"- .291" (6.6-7.4)	9/32"	7 #11, 8M	2 1/2" (64)	3/8" (9.5)	3/8" (9.5)	1/2" (12.7)
.292"- .336" (7.4-8.5)	5/16"	7 #10, 10 M	2 1/2" (64)	3/8" (9.5)	3/8" (9.5)	9/16" (14.2)
.337"- .394" (8.6-10)	3/8"	7 #8, 14M, 16M	2 1/2" (64)	7/16" (11.0)	7/16" (11.0)	5/8" (15.8)
.395"- .474" (10-12)	7/16"	7 #7, 18M, 20M	2 1/2" (64)	1/2" (12.7)	1/2" (12.7)	1 1/16" (17.4)
.475"- .515" (12.1-13.1)	**	7 #6	—	9/16" (14.2)	9/16" (14.2)	3/4" (19.0)
.516"- .570" (13.1-14.5)	**	7 #5, 25M	—	5/8" (15.8)	5/8" (15.8)	15/16" (23.7)

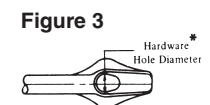
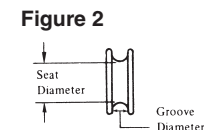
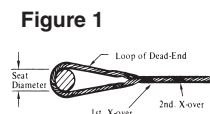

\*Depending on geometric shape of the hole, a hole diameter less than specified may be acceptable.

\*\*Use Big-Grip Dead-ends (Refer to Page 191).

**Note:** Alumoweld® is a registered trademark of the Copperweld Company.



# GUY-GRIP® Dead-end

## Acceptable Fittings

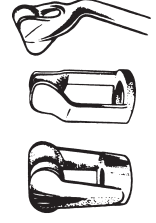
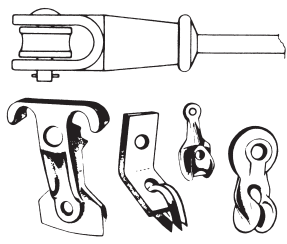
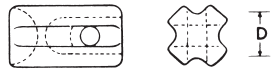
<b>ANCHOR RODS</b>  <p>Anchor Rod Diam.  <table border="1" style="display: inline-table;"> <tr> <td>1/2"</td> <td>5/8"</td> <td>3/4"</td> <td>1"</td> <td>1 1/4"</td> </tr> </table> </p> <p>Loop Diameters 1" to 1 3/8"</p>	1/2"	5/8"	3/4"	1"	1 1/4"	<b>THIMBLE EYE-BOLTS, EYENUTS &amp; EYES</b>  <table border="1" style="display: inline-table;"> <tr> <td>3/8"</td> <td>1/2"</td> <td>5/8"</td> <td>3/4"</td> </tr> </table> <p>Loop Diameters 1" to 2"</p>	3/8"	1/2"	5/8"	3/4"	<b>POLE FITTINGS</b>  <p>Loop Diameters 1" to 2 3/8"</p>	<b>GUY-STRAIN INSULATORS</b>  <table border="1" style="display: inline-table;"> <tr> <th>NEMA</th> <th>D</th> </tr> <tr> <td>54-1</td> <td>1 3/4"</td> </tr> <tr> <td>54-2</td> <td>2 1/8"</td> </tr> <tr> <td>54-3</td> <td>2 3/8"</td> </tr> <tr> <td>54-4</td> <td>2 3/8"</td> </tr> </table> <p>Loop Diameters 1 3/4" to 2 3/8"</p>	NEMA	D	54-1	1 3/4"	54-2	2 1/8"	54-3	2 3/8"	54-4	2 3/8"
1/2"	5/8"	3/4"	1"	1 1/4"																		
3/8"	1/2"	5/8"	3/4"																			
NEMA	D																					
54-1	1 3/4"																					
54-2	2 1/8"																					
54-3	2 3/8"																					
54-4	2 3/8"																					

For Use on Galvanized Steel Strand								
Catalog Number		Size (mm)	Strand Construction	Mean Diameter (mm)	Length (mm)	Color Code	Units Per Carton	Wt./Lbs. Per Carton
B-Coat	C-Coat							
GDE-1102	GDE-2102	3/16" (4.7)	7W	.186" (4.7)	20" (508)	Red	100	30
			7W	.195" (4.7)				
GDE-1104	GDE-2104	1/4" (6.3)	3W	.259" (6.5)	25" (635)	Yellow	50	24
			7W	.240" (6.0)				
GDE-1106	GDE-2106	5/16" (7.9)	3W	.312" (7.9)	31" (788)	Black	50	39
			7W	.312" (7.9)				
			7W	.327" (7.9)				
GDE-1107	GDE-2107	3/8" (9.5)	3W	.356" (7.9)	35" (788)	Orange	50	51
			7W	.360" (9.1)				
GDE-1108	GDE-2108	7/16" (11.0)	7W	.435" (11.0)	38" (965)	Green	25	40

Bezinal® Strand*							
Catalog Number	Size (mm)	Strand Construction	Mean Diameter (mm)	Length (mm)	Color Code	Units Per Carton	Wt./Lbs. Per Carton
BDE-9102	3/16" (4.7)	7W	.186" (5)	20" (508)	Red	100	30
		7W	.195" (5)				
BDE-9104	1/4" (6.3)	3W	.259" (7)	25" (635)	Yellow	50	24
		7W	.240" (6)				
BDE-9106	5/16" (7.9)	3W	.312" (8)	31" (788)	Black	50	39
		7W	.312" (8)				
		7W	.327" (8)				
BDE-9107	3/8" (9.5)	3W	.356" (8)	35" (788)	Orange	50	51
		7W	.360" (9)				
BDE-9108	7/16" (11.0)	7W	.435" (11)	38" (965)	Green	25	40

**Notes:**

1. Left hand lay standard.
  2. Big-Grip Dead-end recommended for guying metal towers and antennas.
- \* Dead-ends manufactured from Bezinal® Material. Bezinal is a registered trademark of the Bekaert Company.

# GUY-GRIP® Dead-end

Aluminum-Clad Steel						
Catalog Number	Mean Diameter (mm)	Nominal Strand Size	Length (mm)	Color Code	Units Per Carton	Wt./Lbs. Per Carton
AWDE-4108	.220" (5.5) .220" (5.5)	4M 3 #10	21" (533)	Green	50	20
AWDE-4110	.242" (6.1) .247" (6.2)	6M 3 #9	24" (610)	yellow	50	20
AWDE-4113	.272" (6.9) .277" (7.0)	8M 3 #8	24" (610)	Blue	50	22
AWDE-4116	.306" (7.7) .306" (7.7) .311" (7.8)	<sup>5</sup> / <sub>16</sub> "—7 #10 10M 3 #7	26" (660)	Black	50	29
AWDE-4119	.343" (8.7) .343" (8.7) .349" (8.8)	<sup>11</sup> / <sub>32</sub> "—7 #10 12.5M 3 #6	29" (737)	Yellow	50	41
AWDE-4120	.363" (9.2)	14M	31" (787)	Blue	50	53
AWDE-4122	.385" (9.7) .386" (9.8) .392" (9.9)	<sup>3</sup> / <sub>8</sub> "—7 #8 16M 3 #5	32" (812)	Orange	50	55
AWDE-4124	.417" (10.5)	18M	34" (864)	Black	25	37
AWDE-4125	.433" (10.9)	<sup>7</sup> / <sub>16</sub> "—7 #7	36" (914)	Green	25	40
AWDE-4126	.444" (11.2)	20M	37" (940)	Yellow	10	22

**Note:** Left hand lay standard. Nominal strand size indicates one of various conductors within each range. Big-Grip Dead-end is recommended for guying metal towers and antennas.

Catalog Number	Size (mm)	Strand Construction	Mean Diameter (mm)	Length (mm)	Color Code	Units Per Carton	Wt./Lbs. Per Carton
Stainless Steel for Type 302 Strand							
SDE-5101	<sup>7</sup> / <sub>32</sub> " (5.5)	3W 7W	.224" (5.6) .216" (5.4)	22" (559)	Blue	100	30
SDE-5102	<sup>1</sup> / <sub>4</sub> " (6.3)	3W 7W	.259" (6.5) .249" (6.3)	26" (660)	Yellow	50	25
SDE-5103	<sup>9</sup> / <sub>32</sub> " (7.1)	7W	.279" (7.0)	27" (686)	Black	50	26
SDE-5104	<sup>15</sup> / <sub>16</sub> " (23.7)	3W 7W	.312" (7.9) .312" (7.9)	31" (787)	Orange	50	41
SDE-5105	<sup>3</sup> / <sub>8</sub> " (9.5)	3W 7W	.356" (9.0) .360" (9.1)	37" (940)	Green	50	66
Stainless Steel for Type 430 Strand							
SDE-5106	<sup>7</sup> / <sub>16</sub> " (11.0)	7W	.435" (11.0)	43" (1092)	Red	25	53
Stainless Steel for Type 316 Strand							
SDE-6101	<sup>7</sup> / <sub>32</sub> " (5.5)	3W 7W	.224" (5.6) .216" (5.4)	22" (559)	Blue	100	29
SDE-6102	<sup>1</sup> / <sub>4</sub> " (6.3)	3W 7W	.259" (6.5) .249" (6.3)	26" (660)	Yellow	50	25
SDE-6103	<sup>9</sup> / <sub>32</sub> " (7.1)	7W	.279" (7.0)	27" (686)	Black	50	26
SDE-6504*	<sup>8</sup> / <sub>16</sub> " (7.9)	3W 7W	.312" (7.9) .312" (7.9)	31" (787)	Orange	50	41
SDE-6105	<sup>3</sup> / <sub>8</sub> " (9.5)	3W 7W	.356" (9.0) .360" (9.1)	37" (940)	Green	50	66

**Note:** Left hand lay standard. GUY-GRIP Dead-ends for copper-covered steel are also available.

\*These Dead-ends utilize the open helix loop design.



# Big-Grip Dead-end

Big-Grip Dead-ends are designed for use with antenna, communications tower, microwave and various guyed structures that require use of large guy strand. They are effective at both the structure top and the anchor bottom.

Big-Grip Dead-ends are left hand lay standard and are applied to the same basic materials as the strand (galvanized strand, aluminum covered strand, except where noted differently).

The Big-Grip Dead-end is designed to be applied quickly in the field, without tools, and usually by one person.

Concentrated stresses in the anchor area are minimized by the cabled loop. Long length helical gripping distributes other stresses uniformly and evenly.

For more detailed information concerning installation guidelines contact Preformed Line Products.

## Galvanized Strand

For use on:

- Extra High Strength
- High Strength
- Siemens Martin
- Utilities Grade



Catalog Number	Size (mm)	Strand Construction	Actual Diameter (mm)	BG Per Carton		Approx. Length (m)	Color Code	Rated Holding Strength	% of Strand's Rated Breaking Strength
				Units	Wt/ Lbs				
BG-2115	1/2" (12.7)	7W or 19W	.495"(12.5) or .500"(12.7)	20	63	49" (1.24)	Blue	26,900#	(100%)
BG-2116	9/16" (14.2)	7W or 19W	.564"(14.3) or .565" (14.3)	10	48	55" (1.39)	Yellow	35,000#	(100%)
BG-2111	5/8" (15.8)	7W or 19W	.621"(15.7) or .625"(15.8)	10	65	64" (1.62)	Black	40,200#	(100%)
BG-2112	3/4" (19.0)	19W	.750"(19.0)	5	54	76" (1.93)	Orange	58,300#	(100%)
*BG-MS-7023	7/8" (22.2)	19W	.885"(22.4)	3	47	90" (2.28)	Green	79,700#	(100%)
*BG-MS-7047	1" (25.4)	19W or 37W	1.000"(25.4) or 1.001"(25.4)	3	76	125" (3.17)	Blue	104,500# 92,430#	(100%) (90%)

**Note:** Left Hand Lay Standard.

\*Manufactured of Alumoweld® material. Alumoweld is a registered trademark of the Copperweld Co.

Strand Diameter (mm)	Nominal Strand (mm)	Seat Dimensions		Minimum Groove Diameter (mm)	Minimum Hardware Hole Diam. (mm)	Thimble Size (mm)	Pin Diameters		Double Extra Strong Weight Pipe		
		Min. (mm)	Max. (mm)				Min. (mm)	Max. (mm)	Nominal Size (mm)	O.D.	I.D.
.475"-.515" (12-18)	1/2" (12.7)	1 3/8" (34.9)	2 3/8" (60.3)	9/16" (14.2)	3/4" (19.0)	5/8" (15.8)	1" (25.4)	1 5/8" (41.2)	1 1/4" (31.7)	1.66	.896
.516"-.570" (13-14)	9/16" (14.2)	1 1/2" (38.1)	2 5/8" (66.6)	5/8" (15.8)	15/16" (23.7)	5/8" (15.8)	1 1/8" (28.5)	1 5/8" (41.2)	1 1/4" (31.7)	1.66	.896
.571"-.635" (15-16)	5/8" (15.8)	2" (50.8)	2 5/8" (66.6)	3/4" (19.0)	1" (25.4)	3/4" (19.0)	1 1/2" (38.1)	1 7/8" (47.6)	1 1/4" (31.7)	1.66	.896
.636"-.772" (16-20)	3/4" (19.0)	2 1/2" (63.5)	3 1/8" (79.3)	7/8" (22.2)	1 3/16" (30.1)	7/8" (22.0)	1 7/8" (47.6)	2 1/8" (53.9)	1 1/2" (38.1)	1.9	1.1
.773"-.868" (20-22)	-	2 1/2" (63.5)	3 5/8" (92.0)	1" (25.4)	1 3/8" (34.9)	1" (25.4)	2" (50.8)	2 3/8" (60.3)	2" (50.8)	2.375	1.503
.869"-.1.024" (22-26)	1" (25.4)	3" (76.2)	4 1/8" (104.7)	1" (25.4)	1 3/8" (34.9)	1 1/8"-1 1/4" (28.5-31.7)	2 3/8" (60.3)	2 3/4" (69.8)	2" (50.8)	2.375	1.503
1.025"-.1.27" (26-32)	-	3 1/2" (88.9)	5 1/8" (130.1)	1 3/8" (34.9)	1 3/4" (44.4)	1 1/4"-1 3/8" (31.7-34.9)"	2 3/4" (69.8)	3 1/4" (82.5)	2 1/2" (63.5)	2.875	1.771
1.30" (33)	-	4" (101.6)	5 1/8" (130.1)	1 3/8" (34.9)	1 15/16" (49.1)	1 3/8"-1 1/2" (34.9-38.1)	2 7/8" (73.0)	3 3/8" (85.7)	2 1/2" (63.5)	2.875	1.771
Figure 1.	Figure 2.	Figure 3.	Figure 4.	Figure 5.	Figure 6.						

# Big-Grip Dead-end

For Use On: Aluminum Covered Steel Strand										
Catalog Number	Strand Diameter Range		Nominal Strand Size	BG Per Carton		Approx. Length		Color Code	Rated Holding Strength	% of Strand's Rated Breaking Strength
	Min. Inches	Max. Inches		Units	Wt.-Lbs.	Inches	Meters			
BG-4168	.475	.494	7#6	25	60	42	1.06	Blue	22,730#	(100%)
BG-4169	.495	.515	19#10	25	62	44	1.11	Green	27,190#	(100%)
BG-4170	.516	.536	25M	20	66	47	1.19	Red	25,000#	(100%)
BG-4171	.537	.555	7#5	20	67	48	1.21	Yellow	27,030#	(100%)
BG-4172	.556	.570	—	15	68	49	1.24	Blue	33,330#	—
BG-4173	.571	.591	19#9	20	68	50	1.27	Orange	34,290#	(100%)
BG-4174	.592	.612	—	15	50	50	1.27	Green	34,500#	—
BG-4175	.613	.635	—	10	49	54	1.37	Yellow	45,000#	—
BG-4176	.636	.661	19#8	10	50	56	1.42	Black	43,240#	(100%)
BG-4177	.662	.686	19 x .1363"	10	66	59	1.49	Blue	47,400#	(100%)
BG-4178	.687	.712	—	10	68	61	1.54	Red	54,200#	—
BG-4179	.713	.741	19#7 37#10	10	70	63	1.60	Black	51,730# 50,300#	(100%) (95%)
BG-4180	.742	.772	19 x .1499"	5	41	71	1.80	Yellow	54,300#	—
Catalog Number	Actual Diameter Inches		Nominal Strand Size	BG Per Carton		Approx. Length		Color Code	Rated Holding Strength	% of Strand's Rated Breaking Strength
				Units	Wt.-Lbs.	Inches	Inches			
BG-4181	.792		19 x .1584"	5	50	80	2.03	Blue	59,000#	—
BG-4183	.801, .810, .827		37#9 19#6 19 x .1660"	5	69	84	2.13	Green	63,430# 61,700# 63,000#	(95%) (100%) (100%)
BG-4185	.849, .850, .866		37 x .1213" 19 x .170" 19 x .1732" 37 x .1237"	5	68	87	2.21	Black	71,250# 66,000# 68,500# 74,100#	(95%) (100%) (100%) (95%)
BG-4186	.899		37#8	5	76	91	2.31	Yellow	80,000#	(95%)
BG-4187	.910, .934		19#5 19 x .1868"	5	78	93	2.36	Blue	73,350# 75,000#	(100%) (100%)
BG-4188	.981		37# .1401"	4	55	95	2.41	Red	90,250#	(95%)
BG-4189	1.01		37#7	4	85	106	2.74	Green	90,600#	(90%)
BG-4190	1.10		37 x .1571"	3	87	117	2.97	Black	101,700#	(90%)
BG-4191	1.134		37#6	3	86	120	3.04	Yellow	108,200#	(90%)
BG-4192	1.27		37#5	2	87	151	3.83	Red	127,000#	(89%)

**Note:** Left Hand Lay Standard.



# False Dead-end

## False Dead-ends

PREFORMED False Dead-ends are a fast, safe, and economical method for false dead-ending strand. They are designed to be easily applied without any special tools, and because False Dead-ends are made from the same material as the strand, they will hold the same published rated breaking strength.

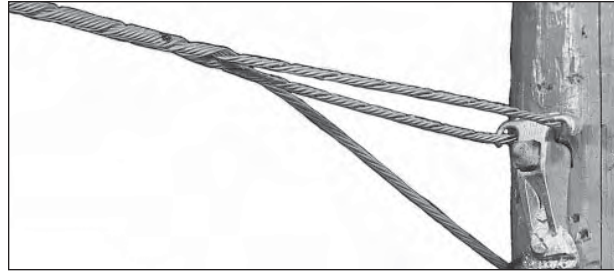

Galvanized Steel, C-Coat for use on Extra High Strength or Utility Grade Strands						
Catalog Number	Strand 7-Wire	Mean Diameter	Length	Color Code	Units Per Carton	Wt./Lbs. Per Carton
GFDE-2121	1/4"	.240"	36"	Yellow	25	17
GFDE-2123	5/16"	.327"	39"	Black	25	24
GFDE-2124	3/8"	.360"	42"	Orange	25	30
GFDE-2125	7/16"	.435"	48"	Green	25	52
GFDE-2126	1/2"	.495"	50"	Blue	25	71

**Note:** Left Hand Lay Standard.

For use on Bezinat® Strand						
Catalog Number	Strand 7-Wire	Mean Diameter	Length	Color Code	Units Per Carton	Wt./Lbs. Per Carton
BFDE-9121	1/4"	.240"	36"	Yellow	25	17
BFDE-9123	5/16"	.327"	39"	Black	25	24
BFDE-9124	3/8"	.360"	42"	Orange	25	30
BFDE-9125	7/16"	.435"	48"	Green	25	52
BFDE-9126	1/2"	.495"	50"	Blue	25	71

**Note:** Left Hand Lay Standard.

Manufactured from Bezinat® Material. Bezinat is a registered trademark of the Bekaert Corporation

# Open Wire Dead-end

## Open Wire Dead-ends

PREFORMED™ Dead-ends for Open Wire are designed to be applied by hand in seconds without tools. They exert uniform, positive, gentle gripping. Holding power extends throughout their full length and prevents the concentration of stress points that cause premature line failure. Trim and modern in appearance, they are made of the same material as the conductor to which they are applied and are performance proven even under various climate extremes.

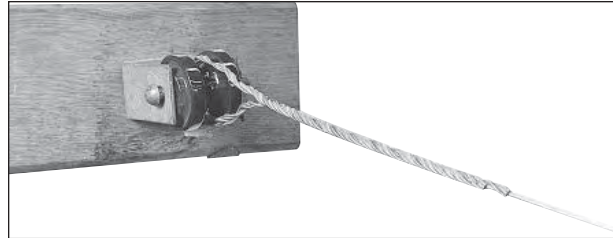

Catalog Number	Wire Gauge	Wire Size	Length	Color Code	Units Per Carton	Wt./Lbs. Per Carton
<b>Galvanized Steel</b>						
GDE-2500	BWG-14	.083"	12"	Yellow	100	6
GDE-2501	BWG-12	.109"	12"	Black	100	9
GDE-2503	BWG-10	.134"	14"	Orange	100	15
<b>Aluminum Clad Steel</b>						
2004511	AWG-11	.091"-.095"	11"	Green	100	7
<b>Copper-Clad Steel</b>						
CWDE-5507	AWG-12	.080"-.081"	11"	Green	100	8
CWDE-5508	AWG-11	.091"-.095"	12"	Red	100	9
CWDE-5509	AWG-10	.102"-.104"	12"	Blue	100	12
CWDE-5510	AWG-9	.114"	13"	Orange	100	13
CWDE-5511	AWG-8	.128"	13"	Black	100	16
CWDE-5512	AWG-6	.162"	16"	Green	100	21



# Drop Wire/C-Rural/Buried Line Wire Dead-ends

## Drop Wire Dead-ends

PREFORMED™ Drop Wire Dead-ends provide an easy, low-cost way to support service drop wire without bail failures or stripping of the insulation. Rapidly applied by hand without tools, they are adjusted to exert firm uniform holding power throughout their length, without crushing or damaging drop wire. Wrap-on design prevents potentially damaging stress points. PREFORMED Drop Wire Dead-ends present a trim, neat appearance, and are manufactured of neoprene-coated stainless steel for added protection against the elements.



Stainless Steel Neoprene Coated					
Catalog Number	Manufacturer	Manufacturer's Designation	Color Code	Units Per Carton	Wt./Lbs. Per Carton
NDE-9500	Alphaduct	PDCW Parallel (N-182)	Black	100	9
	Alphaduct	PDCW Parallel Dumbbell (NE-182)	Black	100	9
	Alphaduct	PDCW Parallel Reinforced (NR-182)	Black	100	9
	Whitney-Blake	TCWP Parallel (2#18)	Black	100	9
	Whitney-Blake	TBP Parallel Reinforced (2#17)	Black	100	9
NDE-9501	AT & T	Bell Reinforced (2#18)	Green	100	9
	Whitney-Blake	TBP-R Parallel Reinforced (2#17)	Green	100	9



## C-Rural Dead-ends

PREFORMED™ C-Rural Wire Dead-ends are an inexpensive way of safely dead-ending one pair aerial distribution wire to a drive hook or eye bolt. They are designed to keep the lines up and costs down by simple hand application without tools of any kind. Their design assures long maintenance free service life.

## Buried Line Wire Dead-ends

Buried Line Wire Dead-ends are used for overhead construction applications of buried line wire.

Catalog Number	Wire Sizes	Length	Color Code	Units Per Carton	Wts./Lbs. Per Carton
<b>Buried Line Wire Dead-ends</b>					
NDE-8500	2 #19 Copper	21" (533)	Red	100	17
NDE-8501	2 #16 Copper	23" (584)	Blue	100	26
<b>C-Rural Dead-ends</b>					
NDE-8502*	2 #14 CW	22" (559)	White	200	30
NDE-8503*	2 #12 CW (or .083 Steel)	30" (762)	Yellow	250	55
NDE-9502*	2 #14 CW	15" (381)	Orange	500	50

**\*Note:** Attachments specifically designed for use with High Density Linear Polyethylene One-Pair Aerial Distribution Wire also may be used with conventional polyethylene covered C-Rural Wire.

# Telegrip

## Telegrip

Telegrips are designed for service drop applications of coaxial cables. Flexible but firm, Telegrips exceed mechanical holding requirements for coaxial cable. The long length design reduces stress levels and eliminates the possibility of crushing the cable or affecting its dielectric properties. Also, its unique gripping principle prevents bending that can cause "snow" or distortion of the television picture.

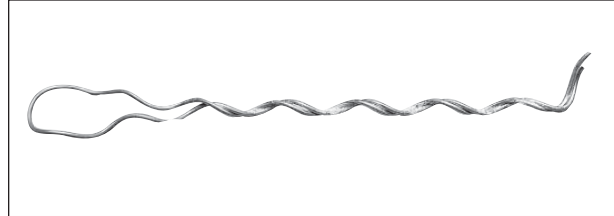

Telegrip			
Catalog Number	Cable Type (mm)	Units Per Carton	Wt/Lbs Per Carton
DE-1500	.242" (6) RG59/U .275" (7) RG6/U	500	23
DE-1600	.242" X .504" (6 x 13) DUAL RG59U	500	25
	.275" X .546" (7 x 14) DUAL RG6/U	500	25
DE-1601	.312" - .315" (8 - 8) QUAD RG6/U	500	25

Consult PLP for requirements not listed.



# Custom Coaxial Dead-end

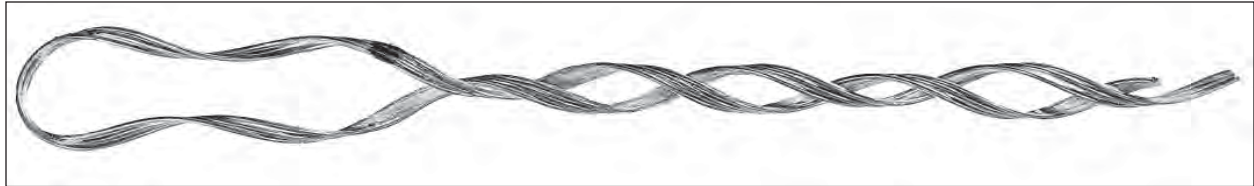

## Coaxial Dead-ends

Custom Coaxial and Dual Coaxial Dead-ends are performance-proven dead-end designs for RG-59/U, Dual RG-59/U, Dual RG-6/U, and RG-11/U coaxial cable. In addition to the inherent benefits of the basic Telegrip, these premium products feature twin leg construction which cushion and relieve gripping stresses created by unusually high winds and heavy ice loading. They are especially recommended for foam insulated coaxial cable and areas where there are extreme corrosive and demanding environmental conditions.

Catalog Number	Cable Type (mm)	Units Per Carton	Wt./Lbs. Per Carton
<b>Custom Coaxial Dead-End</b>			
DE-3329*	RG59/U .242" (6.1)	200	9
<b>Dual Coaxial Dead-End</b>			
DE-2519	DUAL RG59/U .242" X .504" (6.1 x 12.8)	200	20
DE-2520	DUAL RG6/U .275" X .546" (6.9 x 13.8)	200	43
<b>Coaxial Dead-End</b>			
DE-2518	RG11/U .405" (10.2)	200	22

\*Manufactured from stainless steel

# Pulling Eye

## Pulling Eye

PREFORMED™ Pulling Eye is the fastest, most practical means of installing GUY-GRIP® Dead-ends at the anchor rod. The large eye is designed to avoid conflict with the chain hoist. The keeper bolt is adjustable for rod size. Pulling Eye is made of corrosion-resistant nodular iron, finished in orange vinyl coating for added durability against bad weather and rough handling. The keeper bolt is made of specially heat-treated extra high strength steel. The PREFORMED Pulling Eye capacity is 3,000 lbs.



Catalog Number	Description	Standard Carton
<b>Anchor Rod Application</b>		
PE-0300	Pulling Eye	4 Units
<b>Replacement Parts</b>		
PE-A-0002	Pulling Eye: Keeper	As Required
PE-B-2019	Pulling Eye: Bolt	As Required
PE-C-0607	Pulling Eye: Nut	As Required



# Safety Guy Wire Dispenser

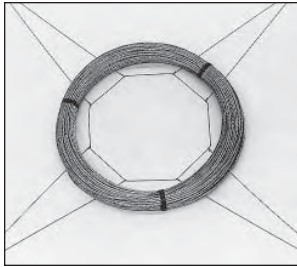

1. Fold out legs.

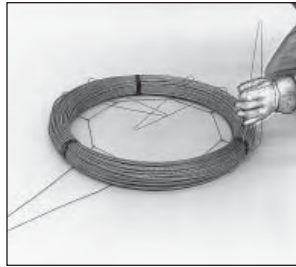

2. Bend legs over coil.



3. Twist at least two inches of legs together until wire cage is tight.



4. Turn wire cage over and pay-out from side Tuck end back into the cage.

## Safety Guy-Wire Dispenser

**NO MORE RUNAWAYS.** PREFORMED™ Safety Guy-Wire Dispenser is designed to provide safe, easy, completely controlled handling and paying-out of strand coils up to 500 ft. in length, including EHS strand. It also can be used with wire, wire rope, cable, conductor, etc. Eliminate weight lifting, handling struggle, and the hazards of “runaway” coil ends. Small and light in weight (a carton of 50 weighs only 22 pounds), the Safety Guy-Wire Dispenser occupies minimal truck space. No banding or taping of

coils is necessary. Saves personnel cost (only one person to pay out a loaded coil) and reduces inventory (just one universal size).

PREFORMED Safety Guy-Wire Dispenser accommodates any size coil, provided at least two inches of the end of each leg can be twisted. Designed to withstand the free-fall impact of a 200 pound coil from 15 ft.

Catalog Number	Standard Carton Quantity	Typical Size Coils Accommodated	Leg Length (mm)	Wire Size
SGD-0700 (Standard Size)	50	500' 7/16" 250' 1/2" Strand 23" by 9" Triplex Coils	24" (610)	14 gauge
SGD-0701 (Jumbo Size)	25	500' 1/2" Strand	30" (762)	12 gauge